

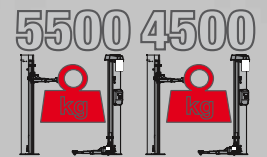

Automotive Equipment

HC5502 - HC4502

EN Electro-hydraulic two post lifts with top connections



C-Line *Lifting Equipment*

Tyre Changers | Wheel Balancers | Wheel Aligners | Lifts | Miscellany

Electro-hydraulic two post lifts with top connections

Electro-hydraulic two post lifts with top connections. Possibility of installation in **symmetrical** or **asymmetric** version. Realignment of the two carriages using metal cables that guarantee excellent synchronisation.

Standard height of two-post connection: 4,050 mm.

Available versions (with optional column extension set):

- **V**: Specific for vans (Height of two-post connection: 4,620 mm).
- **XV**: Specific for vans and very high vehicles, extra-high version (Height of two-post connection: 5,220 mm).

- 1 Internally reinforced column structure** for little bending and internal cable guiding.
- 2 Electro magnet safety release 24V**
- 3 Rubber door protections. Toothed sector arm rotation stop system**
- 4 Four three-section symmetrical arms**

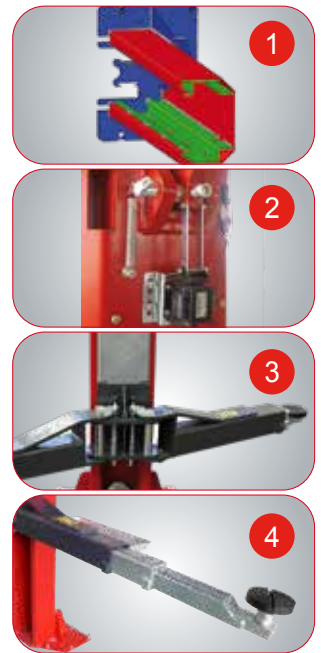

TECHNICAL DATA

	HC5502	HC4502
Lift capacity	5500 kg	4500 kg
Lifting time	45 s	
Three phase motor	400/230V - 3kW - 3Ph - 50/60Hz	
Single phase motor	230V - 3kW - 1Ph - 50/60Hz	
Max. lifting height	2080 mm	
Max. locking position	1957 - 2037 mm	
Lift minimum height	100 mm	
Height connection	4050/4620/5520 mm	

OPTIONAL ACCESSORIES

- A** Column extension set
- B** 8-43300021 Set of 4 extension for pads, H=35 mm
- C** 8-43300014 Set of 4 extension for pads, H=80 mm
- D** 8-43300015 Set of 4 extension for pads, H=140 mm
- E** 8-43300016 Set of 4 adapters for Mercedes Sprinter

ACCESSOIRES

All models are equipped with:

- Safety stop-bar.
- Two set of extension pads.

STANDARD



OPTIONAL*

For other optional accessories, refer to separate catalogue

DIMENSIONS

TECO HC5502

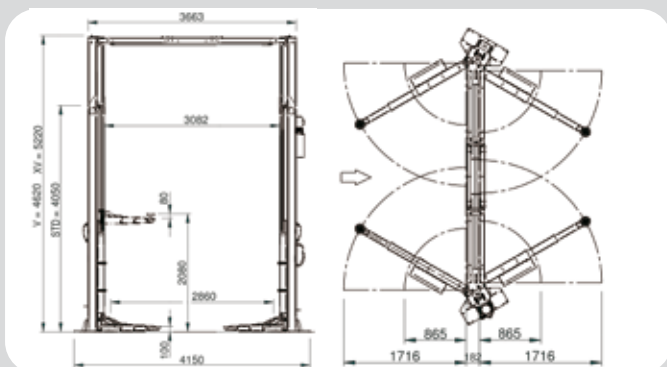

TECO HC4502

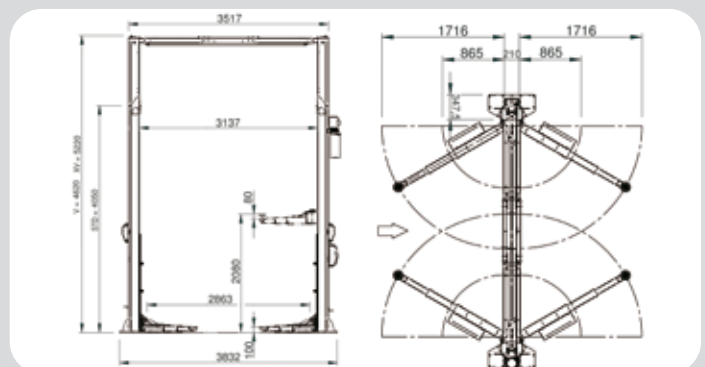

Photographs, features and technical data are not binding, they are subject to change without notice - Cod. DPTC000336_Ed. 07_2021